

ROCK VALVE™ STATIONARY CONCRETE PUMPS

SP 500 / SP 750-15 / SP 750-18 / SP 1000

SP 1000HP / SP 1250 / SP 2000

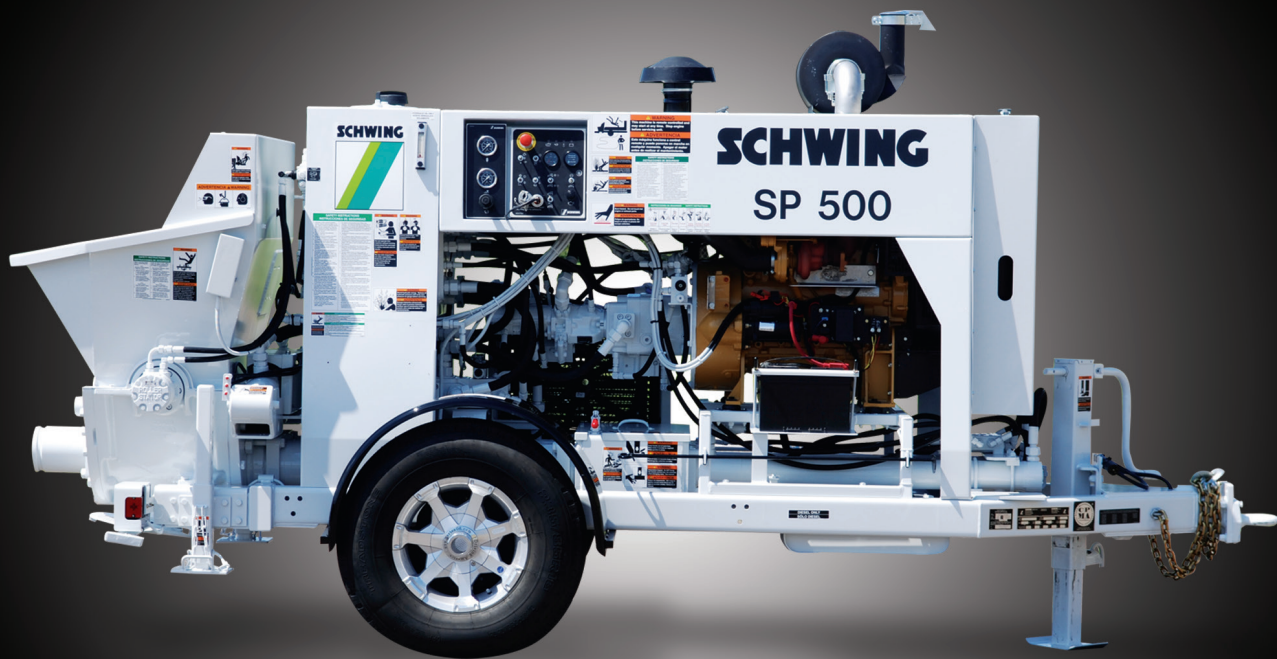

THE CONCRETE, SHOTCRETE OR GROUT PUMP

- Output from 35 to 118 cubic yards per hour
- Pressure from 870 psi to 1568 psi
- Maximum Aggregate Size from .5" to 2.5"

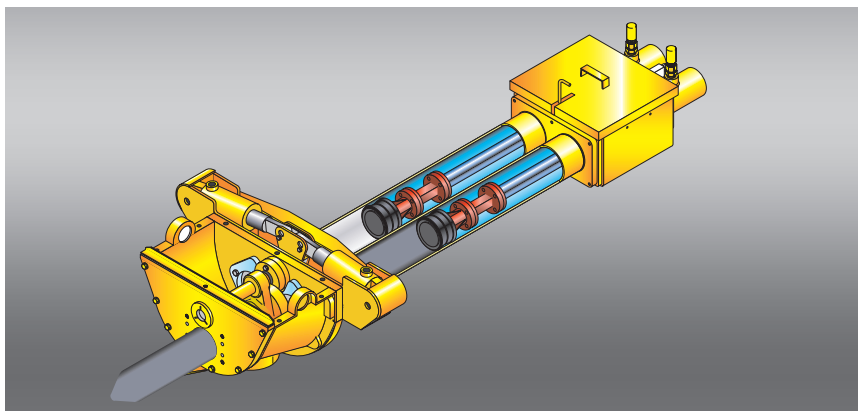

This open loop, all-hydraulic concrete pump sets the standard for fuel-efficiency, reliability and performance. Twin circuit hydraulics combine with standard dual shifting cylinders, agitator and Rock Valve™ to provide smooth pumping of harsh mixes, shotcrete and grout.



Convenient control panel includes electric switches for on/off, forward/reverse and agitator on/off. Tachometer and hour meter are also located here along with E-stop, fuse panel and ignition switch.



Invest in an all-hydraulic concrete pump that incorporates big pump features into a compact, economical package. The SP Series pumps are excellent entry level, all-around performers as well as seasoned professional machines pumping grout, shotcrete and structural concrete with output up to 118 yards per hour and pumping pressure up to 1568 psi. At the heart of these concrete pumps is the Rock Valve™ which is used on all of the Schwing boom pumps. With the lowest cost per yard of operating costs, the Rock Valve™ is your guarantee of profitable pumping of the harshest mixes. This is the only sequencing valve that is completely rebuildable adding to long term reliability and maximum utilization.

One call to Schwing puts you in touch with pumping expertise and a full range of accessories so you are ready for new pumping challenges and profits. Because your SP model is patterned on larger Schwing models, you are guaranteed legendary reliability that has been proven on thousands of projects. Whether your pump is your livelihood or part of a larger equipment fleet, purchase with the confidence that only a Schwing can provide.



Remote control (cable or optional radio remote) frees the operator to monitor the end hose and the pump. Critical functions including on/off and forward/reverse are at your fingertips.



Fuel efficient CAT® diesel engines are an example of the high quality components on our stationary pumps. This engine was designed for construction applications and is up to the reliability standards of a Schwing pump.



The Rock Valve™ cleans out faster, pumps harsher mixes and wastes less concrete than other pumps. The standard hopper agitator keeps harsher mixes flowing to the Rock Valve™ for trouble-free pumping.

SPECIFICATIONS

PUMP SPECIFICATIONS

	SP 500		SP 750-15		SP 750-18	
	U.S.	Metric	U.S.	Metric	U.S.	Metric
Concrete Output Per Hour (cu. yds. - cu. m)	45	35	50	38	70	54
Maximum Pressure on Concrete (psi - bar)	1100	76	1100	76	1100	76
Maximum Aggregate Size (in. - mm)	1.5	37	1.5	37	1.5	37
Concrete Cylinder Diameter (in. - mm)	6	150	6	150	7	180
Differential Piston/Rod Diameter (in. - mm)	3.15/1.96	80/50	3.15/1.96	80/50	3.54/1.96	90/50
Concrete Cylinder Stroke Length (in. - mm)	39	1000	39	1000	39	1000
Maximum Pump Strokes Per Minute	32.5		35		35	
Main Hydraulic Pump	A11V095		A11V095		A11V0130	
Volume Control	0 to Maximum		0 to Maximum		0 to Maximum	
Concrete Valve Type	Long Rock™		Long Rock™		Long Rock™	
Shifting Cylinders	2		2		2	
Hydraulic Tank Capacity (gal - liters)	50	190	50	190	70	265
Hydraulic System	Open Loop		Open Loop		Open Loop	
Hopper Height (in. - mm)	48	1220	48	1220	48	1220
Hopper Capacity (cu. ft. - cu. m)	11	.31	11	.31	11	.31
Outlet Diameter (in. - mm)	5	125	5	125	5	125
Engine Model - Tier III	-		CAT 4.4T		CAT 4.4T	
Engine Model - Tier 4	CAT C3.4B		-		-	
Engine Power (hp - Kw)	74.5	54.7	100	75	100	75
Fuel Tank Capacity (gal - liters)	20	75.7	20	75.7	30	114
Axle	Single Standard		Single Standard		Single Standard	
Axle Capacity Rating (lbs. - kg)	7000	3175	7000	3175	8000	3629
Tires	ST 235/80 R16		ST 235/80 R16		215/75 R17.5	
Dual Axle Tires	-		-		LT 215/85 R16	
Brakes	Electric		Electric		Electric	
Outrigger Legs	Manual Standard		Manual Standard		Manual Standard	
Length (ft.-in. - m)	14-4	4.4	14-4	4.4	15-9	4.8
Width (ft.-in. - m)	5-8	1.7	5-8	1.7	5-10	1.8
Height (ft.-in. - m)	7-3	2.2	7-3	2.2	7-6	2.3
Weight (lbs. - kg)	6500	2948	6600	2994	7500	3402
Remote Control Cable (ft. - m)	100	30.5	100	30.5	100	30.5

Pump specifications are for standard units. Other units are available.

Specifications are subject to change without prior notice.

SP 1000		SP 1000HP		SP 1250		SP 2000 (Rod/Piston)	
U.S.	Metric	U.S.	Metric	U.S.	Metric	U.S.	Metric
70	54	35	27	95	73	118/91	91/70
1100	76	1450	100	942	65	870/1568	60/108
1.5	37	.5	13	1.5	37	2.5	63.5
7	180	6	150	7	180	8	200
3.54/1.96	90/50	3.54/1.96	90/50	3.15/2.16	80/55	4.72/3.14	120/80
39	1000	39	1000	55	1400	63	1600
35		26		34		30/23	
A11V0130		A11V0130		A11VL0130		A11VL0190	
0 to Maximum		0 to Maximum		0 to Maximum		0 to Maximum	
Long Rock™		HP Short Rock		Long Rock™		M Rock	
2		2		2		2	
70	265	70	265	98	371	100	379
Open Loop		Open Loop		Open Loop		Open Loop	
48	1220	48	1220	54	1373	54	1373
11	.31	11	.31	11	.31	21	.60
5	125	4	100	5	125	7	180
CAT 4.4 TA-ECU		CAT 4.4 TA-ECU		CAT 6.6 TA-ECU		CAT 6.6 TA-EDU	
–		–		–		–	
139	104	139	104	174	129.5	174	129.5
30	114	30	114	50	189	50	189
Single Standard		Single Standard		Dual Standard		Dual Standard	
8000	3629	8000	3629	13000	5897	13000	5897
215/75 R17.5		215/75 R17.5		–		–	
LT 215/85 R16		–		LT 215/85 R16		LT 215/85 R16	
Electric		Electric		Electric		Electric	
Manual Standard		Manual Standard		Hydraulic Standard		Manual Standard	
15-9	4.8	15-9	4.8	17-9	5.4	19-9	6
5-10	1.8	5-10	1.8	6-8	2	6-8	2
7-6	2.3	7-6	2.3	8-2	2.5	8-2	2.5
7580	3438	7580	3438	10400	4717	12620	5724
100	30.5	100	30.5	100	30.5	100	30.5

OUTPUT CHARTS

SP 500

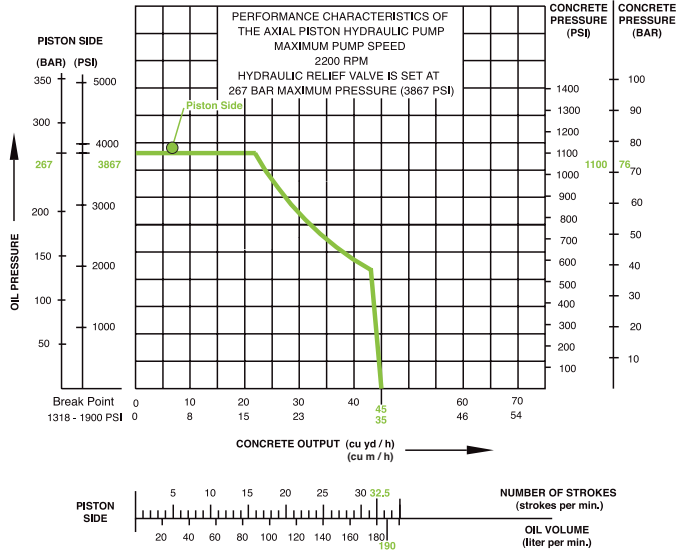

SP 750-15

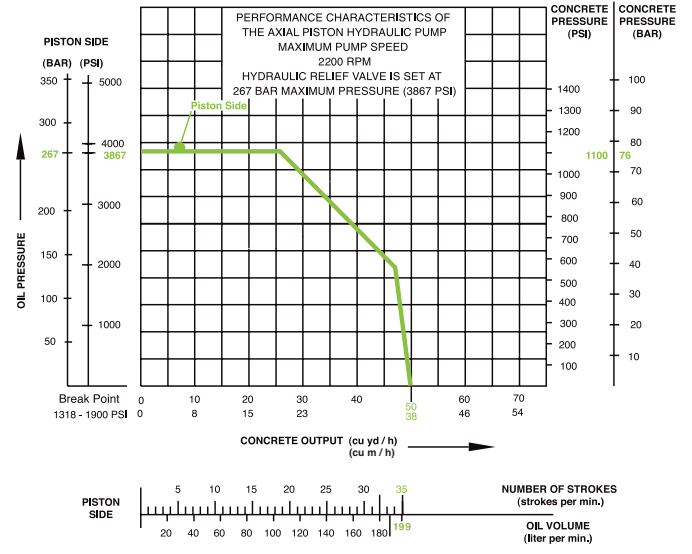

SP 1000HP

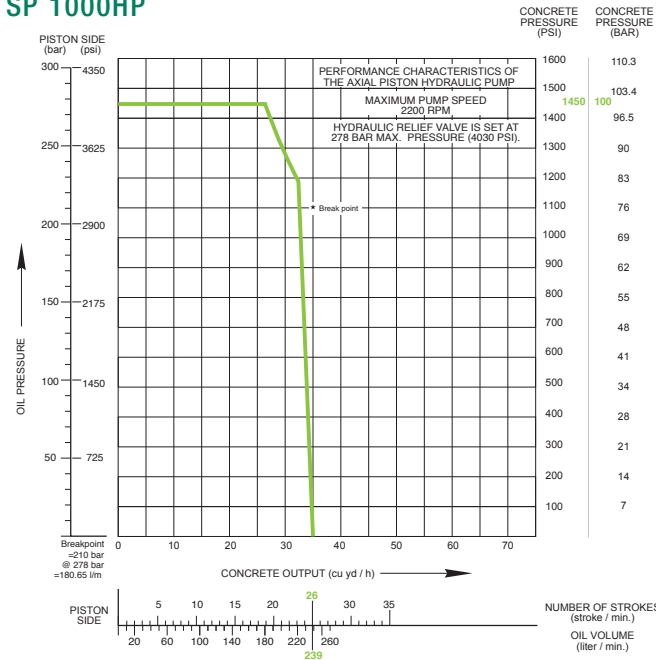

SP 1250



SP 750-18

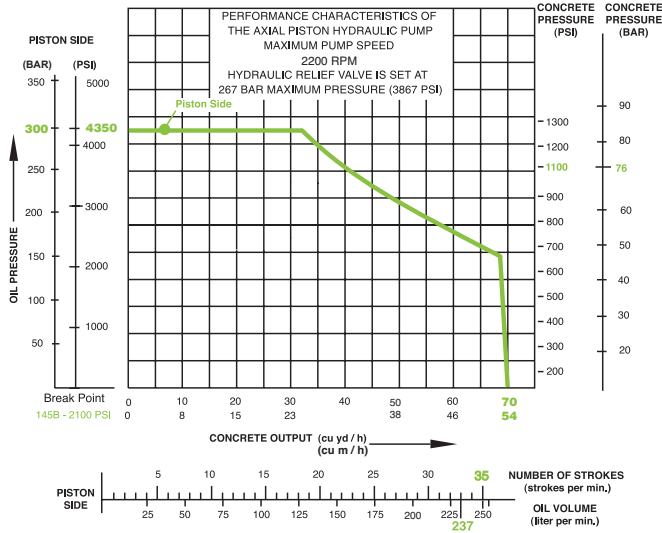

SP 1000

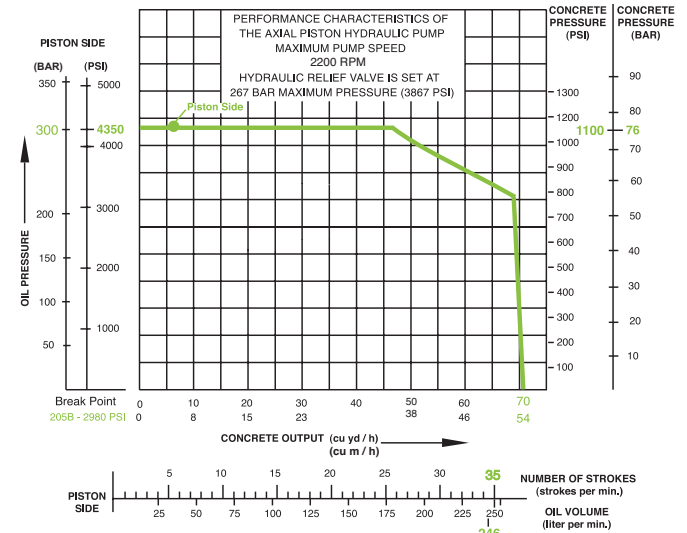

SP 2000

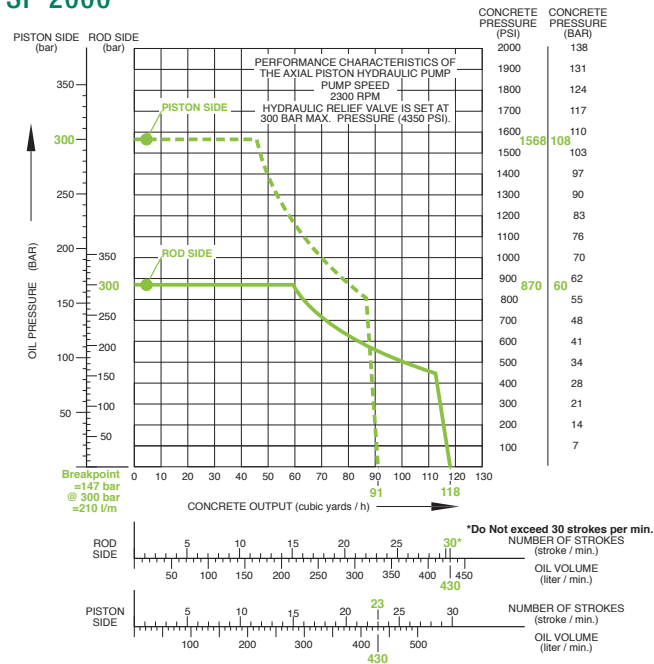



More than 400,000 square feet are devoted to producing the highest quality concrete equipment at our White Bear, Minnesota plant. From close inspection of incoming materials to forming our products with the latest robotic welding techniques, Schwing takes craftsmanship to the highest standards. In addition, a vast inventory of parts are on hand to keep your Schwing product running at maximum efficiency. Please schedule a visit to this modern facility located minutes north of Minneapolis/ St. Paul to see our long-term commitment to the market.

Only one manufacturer can supply the Schwing experience.

Thousands of our customers form a backdrop of success that you can join by letting us spec the right piece of equipment for your needs. And a select group of knowledgeable dealers provide another layer of invaluable experience. You and your staff will be welcomed into our dedicated training facility to learn how to extract the maximum profitability from your Schwing. And your investment is backed by Schwing's industry leading service, training and parts.

SCHWING-STETTER MOVES CONCRETE. **WORLDWIDE.**

Wherever concrete is produced and moved is where you will find Schwing-Stetter machinery.

With plants in Germany, Austria, USA, Brazil, Russia, China and India as well as with more than 100 sales and service facilities, the group of companies is always close to the customer.

Our wide range of products with something for every application is what makes Schwing-Stetter the No. 1 system supplier for concrete machinery worldwide.



CONCRETE
BATCHING PLANTS



TRUCK
MIXERS



TRUCK-MOUNTED
CONCRETE PUMPS



STATIONARY
CONCRETE PUMPS



SEPARATE
PLACING BOOMS



CONCRETE
RECYCLERS